

Database Building for the *Newspapers & Periodicals of the African Diaspora*

Lyndi Finifrock, Dan Hartwig, Paul Lynch, Barry Osborne

December 12, 2003



Still, even those efforts are not to be spoken of without regret, for they were mainly contained within the narrow limits of pamphlets, or the volumes of newspapers, ephemeral caskets, whose destruction entails the destruction of the gems which they contain.

- From an 1853 edition of *Frederick Douglass' Paper* on the fate of African-American publishing as quoted in Henry Louis Gates Junior's introduction to the *African-American Newspapers and Periodicals: A National Bibliography*.

The African Diaspora covers the globe and has produced countless newspapers and periodicals since the nineteenth century. This intellectual output remains beyond the reach of its members, researchers, educators and interested parties because “of the absence of a comprehensive international documentation strategy for the collection, preservation, and access to these publications.” To rectify this situation, University of Wisconsin-Madison Professor and Librarian James P. Danky has set into motion the *Newspaper & Periodicals of the African Diaspora* project, which will cover the Diaspora in regions beyond North America.¹ This project will serve as a companion to the Danky-edited *African-American Newspapers and Periodicals: A National Bibliography*, which was published in book form in 1998. Unlike its predecessor, however, Danky envisions this new project as an online database, one that circumvents the cost and rigidity of traditional publishing by allowing easier and cheaper access for users as well as greater malleability for those contributing to it.

To achieve this, the project requires not only the input from scholars throughout the world, and patience (Danky estimates this effort will take ten to fifteen years), but also a database with a sound structure equipped to handle potentially tens of thousands of records.² These tasks become even more Herculean when one considers that this project is currently self-funded by Danky who is assisted only by “library school students in a number of different classes,” including collection development and database design & management. At this stage of the project Danky is focusing on a pilot database and web interface to experiment with and perfect before unveiling to various foundations and institutes for more formal funding. Despite these challenges, Danky sees the key to the

¹ *Newspapers & Periodicals of the African Diaspora*, James P. Danky ©2002, <http://mendota.english.wisc.edu/~danky/diaspora>.

² *Newspapers & Periodicals of the African Diaspora*, <http://mendota.english.wisc.edu/~danky/diaspora>.

project's success as being "to figure out how to do the work in Europe, and later in South America and Asia."³

Due to the nature of the resources eligible for this project, the *Newspaper & Periodicals of the African Diaspora* project requires a database able to track newspapers, magazines, serials and other pamphlets which represent publishers and audiences not only in the country of publication, but also audiences residing in another country and potentially a plurality of countries. Doing so requires the ability to track multiple languages, addresses, subjects, themes and formats. In creating a Microsoft Access database for the project all of these factors were taken into account. Furthermore, just as the resources entered into the database represent the diversity of the African Diaspora, so too are the potential groups that will work with it, requiring a user-friendly interface. First, it cannot be taken for granted that the researchers and scholars mining the database for information will have the technological skills to work with Access at its most skeletal structure. Second, it is quite likely that those performing data entry tasks will not be familiar with the subjects and publications that they are working with. Therefore the database requires user-friendly formats for the efficient entering and updating of information as well as the running of reports that can call upon attributes representing a combination of 13 simple and composite entities.

To make for easier data entry as well as access by researchers for the running of reports, the database features three main forms that reflect its entity-relational structure:

- AUDIENCE – which takes into account the age and/or gender of the resource's intended audience as well as the nation or nations that this

³ Email from James Danky to Barry Osborne, Tuesday, December 2, 2003 4:53 pm.

audience currently resides in. This form is accessed via a link in the RESOURCE form.

- PUBLISHER – which accounts for the name and address of the resource’s publisher, as well as any variant information on the publisher including the possibility that a publisher might have offices in more than one country. This form provides a link to the RESOURCE form, allowing easy navigation back and forth between RESOURCE and PUBLISHER data entry.
- RESOURCE – captures the specifics of the individual items, e.g. issue of a particular serial or newspaper. This form allows for entry of basic cataloging information such as titles, subtitles, background information on the publication (such as start and end date of publication), individual issue specifics, as well as the particulars of language, format, physical characteristics and price. This form features subforms to enter information on each resource’s CLASSIFICATION (i.e., subject matter), GRAPHICAL CONTENT (e.g., illustrations, figures, etc.) and TEXTUAL CONTENT (i.e., table of contents, reviews, etc.).

All of these three forms are linked together to integrate as seamlessly as possible the cataloging process as a whole.

At the onset, this database must be available on a network to allow for accessibility from multiple users. It is envisioned that – once completed – this database can be offered to users via Internet connections for research purpose.

Figure 1: African Diaspora Database ERD

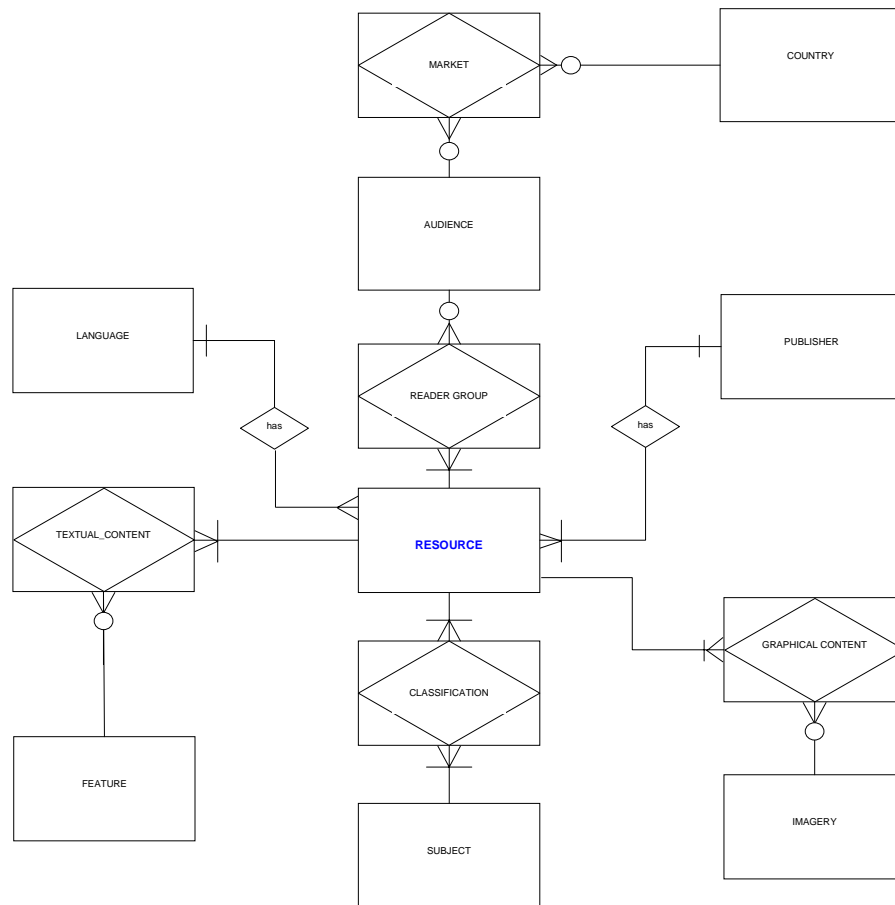
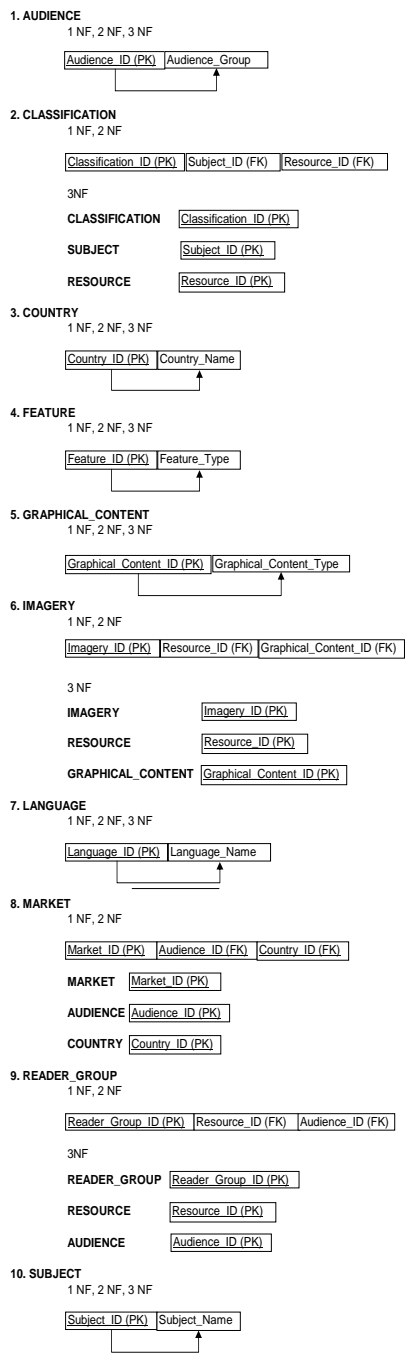
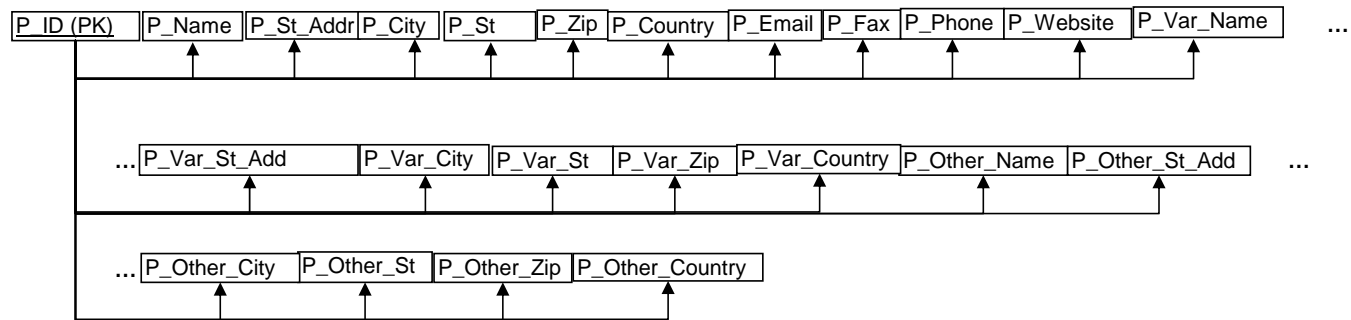

Figure 2: Normalization Tables



12. PUBLISHER

1 NF, 2 NF, 3NF

**13. RESOURCE**

1 NF, 2 NF

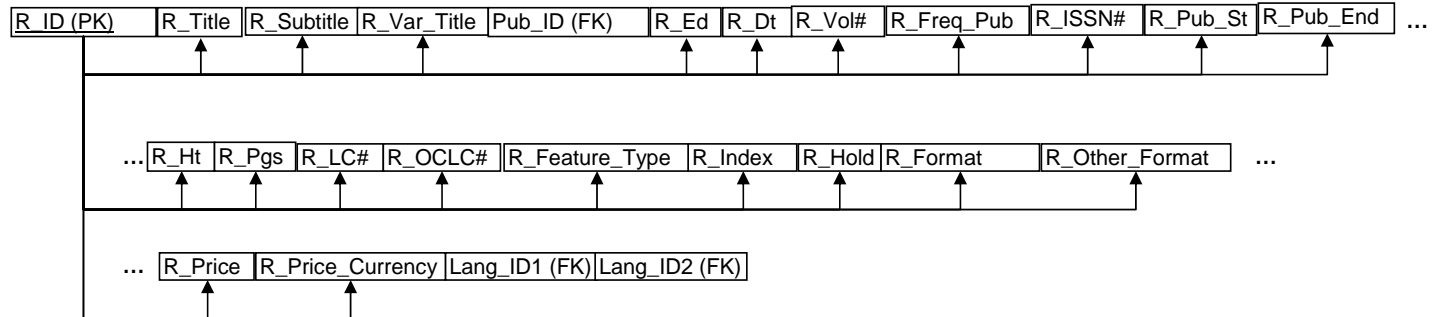

Figure 3: Data Dictionary

TABLE NAME	ATTRIBUTE NAME	DESCRIPTION	TYPE	FORMAT	REQUIRED	PK or FK	FK REFERENCED TABLE
AUDIENCE	Audience_ID	Uniquely identifies target audience group.	AutoNumber		Y	PK	
	Audience_Group	Identifies the age and gender of target audience group.	Text				
CLASSIFICATION	Classification_ID	Uniquely identifies the classification of a resource, serving to connect the subject table to the resource table. The primary key for the subject table which indentifies subject of any given resource.	AutoNumber		Y	PK	
	Subject_ID	The primary key for the resource table which uniquely identifies any given resource.	AutoNumber		Y	FK	SUBJECT
COUNTRY	Resource_ID	Uniquely identifies country.	AutoNumber		Y	FK	RESOURCE
	Country_ID	Specifies name of particular country.	AutoNumber			PK	
FEATURE	Country_Name	Uniquely identifies the feature(s) in a resource. Specifies the type(s) of feature(s) included in the resource, i.e. table of contents, reviews, commercial advertising, and editorials.	Text				
	Feature_ID	Uniquely identifies a particular graphic type.	AutoNumber		Y	PK	
GRAPHICAL_CONTENT	Feature_Type	Uniquely identifies imagery group.	Text				
	Graphical_Content_ID	Resource primary key used to uniquely identify a particular resource.	AutoNumber		Y	PK	
IMAGERY	Imagery_ID	Uniquely identifies image style of resource.	AutoNumber			FK	IMAGERY
	Imagery_Type	Identifies type of image present in resource.	Text		Y	PK	
LANGUAGE	Language_ID	Uniquely identifies language.	AutoNumber		Y	PK	
	Language_Name	Specifies the language(s) a resource is written in.	Text				
MARKET	Market_ID	Uniquely identifies market type.	AutoNumber		Y	PK	

TABLE NAME	ATTRIBUTE NAME	DESCRIPTION	TYPE	FORMAT	REQUIRED	PK or FK	FK REFERENCED TABLE
MARKET (cont'd)	Country_ID	Uniquely identifies country.	AutoNumber		Y	FK	COUNTRY
	Audience_ID	Uniquely identifies target audience group.	AutoNumber		Y	FK	AUDIENCE
PUBLISHER	Publisher_ID	Uniquely identifies publisher.	AutoNumber		Y	PK	
	Publisher_Name	Identifies name of publisher.	Text				
	Publisher_St_Address	Identifies street address of publisher.	Text				
	Publisher_City	Identifies city of publisher.	Text				
	Publisher_State	Identifies state of US publisher.	Text				
	Publisher_Zip	Identifies zip code of publisher.	Text				
	Publisher_Country	Identifies country of publisher.	Text				
	Publisher_Email	Identifies email of publisher.	Text				
	Publisher_Fax	Identifies fax number of publisher.	Number				
	Publisher_Website	Identifies website address of publisher.	Text				
	Publisher_Variant_Name	Identifies name of variant publisher.	Text				
	Publisher_Variant_St_Address	Identifies street address of variant publisher.	Text				
	Publisher_Variant_City	Identifies city of variant publisher.	Text				
	Publisher_Variant_State	Identifies the state of a variant US publisher.	Text				
	Publisher_Variant_Zip	Identifies zip code of variant publisher.	Text				
	Publisher_Variant_Country	Identifies country of variant publisher.	Text				
	Publisher_Other_Name	Identifies name of other publisher.	Text				
	Publisher_Other_St_Address	Identifies street address of other publisher.	Text				
	Publisher_Other_City	Identifies city of other publisher.	Text				
Publisher_Other_State	Identifies state of other US publisher.	Text					
Publisher_Other_Zip	Identifies zip code of other publisher.	Text					
Publisher_Other_Country	Identifies country of other publisher.	Text					

TABLE NAME	ATTRIBUTE NAME	DESCRIPTION	TYPE	FORMAT	REQUIRED	PK or FK	FK REFERENCED TABLE
READER_GROUP	Reader_Group_ID	Uniquely identifies reader group.	AutoNumber		Y	PK	
	Resource_ID	Resource primary key used to uniquely identify a particular resource.	AutoNumber			FK	RESOURCE
	Audience_ID	Audience primary key used to uniquely identify a particular audience group.	AutoNumber			FK	AUDIENCE
RESOURCE	Resource_ID	Uniquely identifies resource.	AutoNumber		Y	PK	
	Resource_Title	Identifies name of resource.	Text				
	Resource_Subtitle	Identifies subtitle, if any, of resource.	Text				
	Resource_Variant_Title	Identifies other or variant title of resource.	Text				
	Publisher_ID	Publisher foreign key that uniquely identifies publisher of resource.	Number			FK	PUBLISHER
	Resource_Editor	Identifies editor or person responsible for editorial oversight of resource.	Text				
	Resource_Date	Identifies date of publication, e.g. 11/5/2003.	Date/Time	99/99/0000;0;_			
	Resource_Volume_Number	Identifies volume, issue or other numbering scheme used to identify particular issues or instance of resource.	Number				
	Resource_Frequency_of_Publication	Identifies how often the resource is published.	Text				
	Resource_ISSN	Identifies International Standard Serial Number of resource.	Number				
	Resource_Publication_Start	Identifies year publication was first published.	Date/Time				
	Resource_Publication_End	Identifies year publication ended. Enter 9999 if continuing.	Date/Time				
	Resource_Height	Identifies the height of the resource.	Number	Fixed			
	Resource_Pages	Identifies number of pages in resource.	Number	General			
	Resource_LC#	Identifies Library of Congress catalog number.	Number	General			

TABLE NAME	ATTRIBUTE NAME	DESCRIPTION	TYPE	FORMAT	REQUIRED	PK or FK	FK REFERENCED TABLE
RESOURCE (cont'd)	Resource_OCLC#	Identifies OCLC control number.	Number	General			
	Language_ID1	Language foreign key that identifies the language that the resource is written in.	Number			FK	LANGUAGE
	Language_ID2	Language foreign key that identifies the language that the resource is written in.	Number			FK	LANGUAGE
	Resource_Indexed?	Is the resource indexed?	Yes/No				
	Resource_Holdings	Identifies holdings information for resource, e.g. libraries holding the title, volumes and issues and/or dates held; location within library.	Text				
	Resource_Format	Identifies the format of the resource such as magazine, newsletter, journal, newspaper, website, etc.	Text				
	Resource_Other_Format	Is the resource available in another format? If yes, this field identifies other available formats of resource.	Text				
SUBJECT	Resource_Price	Identifies cost or price of resource.	Currency				
	Resource_Price_Currency	Specifies currency of price.	Text				
TEXTUAL_CONTENT	Subject_ID	Identifies subject name.	AutoNumber		Y	PK	
	Subject_Name	Name(s) of subjects covered in resource.	Text				
	Textual_Content_ID	Primary key that connects resource table and feature table.	AutoNumber		Y	PK	
	Resource_ID	Foreign key uniquely identifying a particular resource.				FK	RESOURCE
	Feature_ID	Foreign key uniquely identifying a particular feature of a resource.				FK	FEATURE

Figure 4: Database Relationships View

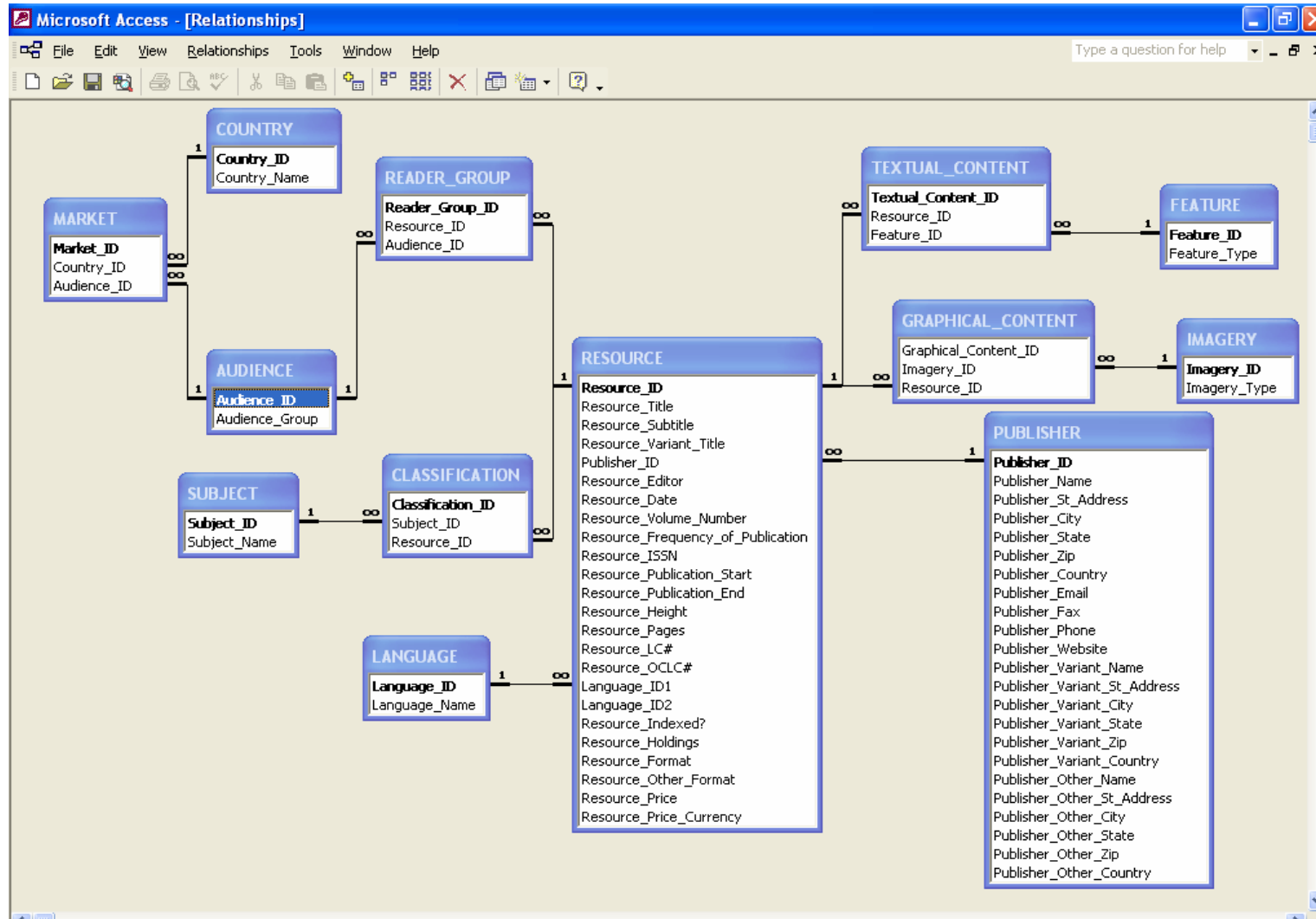

Figure 5: RESOURCE Data Entry Form

RESOURCE

PUBLISHER **AUDIENCE**

Resource_ID: []

Resource_Title: Africa Intelligence

Resource_Subtitle: []

Resource_Variant_Title: []

Resource_Vol_No.: []

Resource_Editor: []

Resource_Date: []

Resource_Freq_of_Pub.: []

Resource_ISSN: []

Resource_Publication_Start: []

Resource_Publication_End: []

Resource_Height: []

Resource_Pages: []

Resource_LC#: []

Resource_OCLC#: []

Resource_Format: []

Resource_Other_Format: []

Language_ID1: []

Language_ID2: []

Resource_Price: []

Resource_Price_Currency: []

Resource Indexed?:

Resource_Holdings: []

CLASSIFICATION

Subject: []

GRAPHICAL CONTENT

Image Type: []

TEXTUAL CONTENT

Feature: []

Record: [] 1 [] of 124

Figure 6: PUBLISHER Data Entry Form

PUBLISHER

RESOURCE

Publisher_ID	873	Publisher_Variant_Name	
Publisher_Name		Publisher_Variant_St_Address	
Publisher_St_Address	142 rue Montmartre F	Publisher_Variant_City	
Publisher_City	Paris	Publisher_Variant_State	
Publisher_State		Publisher_Variant_Zip	
Publisher_Zip	75002	Publisher_Variant_Country	
Publisher_Country	France	Publisher_Other_Name	
Publisher_Email		Publisher_Other_St_Address	
Publisher_Fax		Publisher_Other_City	
Publisher_Phone		Publisher_Other_State	
Publisher_Website		Publisher_Other_Zip	
		Publisher_Other_Country	

Record: 1 of 124

Figure 7: AUDIENCE Data Entry Form

AUDIENCE

	Audience_Group
▶	4

	Country_Name
▶	

Back to Resource

Record: 1 of 3

Figure 8: Sample Report 1

Resources Published in the UK

Resource_Title

Africa Link

AFRICA Today

Africa World Review

African Business

African Soccer

African Study Group

African Times

Alarm

BECDF News

bfn

Black Arts in London

Black Beauty & Hair

Black Business & Culture

Black Perspective

Blackhair

Blues & Soul

B-TS Newsletter

Bulletin of Francophone Africa

Calabash

Cameroon Monitor

Carf Magazine

Caribbean Environment Watch

Christendom

Complete Football International

Crosscolour

Development Team

Focus

Gargamel

Figure 9: Sample Report 2

RESOURCE

Resource_Title Africa Intelligence

Resource_Subtitle

Publisher_Name

Resource_Editor

Publisher_Country France

Resource_Title Africa International

Resource_Subtitle

Publisher_Name

Resource_Editor

Publisher_Country France

Resource_Title Africa Link

Resource_Subtitle International Planned Parenthood Federation's Africa Region Newsletter

Publisher_Name

Resource_Editor

Publisher_Country UK

Resource_Title Africa Live

Resource_Subtitle Politik, Wirtschaft, Kultur

Publisher_Name

Resource_Editor

Publisher_Country Germany

Figure 10: UK Publishers Query

The screenshot shows the Microsoft Access interface for a query named "UK Publishers Query". The design view displays two tables: RESOURCE and PUBLISHER. A relationship line connects the RESOURCE_ID field in the RESOURCE table to the PUBLISHER_ID field in the PUBLISHER table, with a "1" near the PUBLISHER_ID field and an infinity symbol (∞) near the RESOURCE_ID field, indicating a one-to-many relationship.

RESOURCE Table Fields:

- Resource_ID
- Resource_Title
- Resource_Subtitle
- Resource_Variant_Title
- Publisher_ID
- Resource_Editor
- Resource_Date
- Resource_Volume_Number
- Resource_Frequency_of_Publication
- Resource_ISSN
- Resource_Publication_Start
- Resource_Publication_End
- Resource_Height
- Resource_Pages
- Resource_LC#
- Resource_OCLC#
- Language_ID1
- Language_ID2
- Resource_Indexed?
- Resource_Holdings
- Resource_Format
- Resource_Other_Format
- Resource_Price
- Resource_Price_Currency

PUBLISHER Table Fields:

- Publisher_ID
- Publisher_Name
- Publisher_St_Address
- Publisher_City
- Publisher_State
- Publisher_Zip
- Publisher_Country
- Publisher_Email
- Publisher_Fax
- Publisher_Phone
- Publisher_Website
- Publisher_Variant_Name
- Publisher_Variant_St_Address
- Publisher_Variant_City
- Publisher_Variant_State
- Publisher_Variant_Zip
- Publisher_Variant_Country
- Publisher_Other_Name
- Publisher_Other_St_Address
- Publisher_Other_City
- Publisher_Other_State
- Publisher_Other_Zip
- Publisher_Other_Country

Field Selection Grid:

Field:	Resource_Title	Publisher_Country							
Table:	RESOURCE	PUBLISHER							
Sort:									
Show:	<input checked="" type="checkbox"/>	<input checked="" type="checkbox"/>	<input type="checkbox"/>	<input type="checkbox"/>	<input type="checkbox"/>	<input type="checkbox"/>	<input type="checkbox"/>	<input type="checkbox"/>	<input type="checkbox"/>
Criteria:		"UK"							
or:									

The status bar at the bottom of the window shows "Ready" on the left and "NUM" on the right.

Figure 11: UK Publishers Query Output

Microsoft Access - [Resource: UK Publishers Query : Select Query]

File Edit View Insert Format Records Tools Window Help

Resource_Title	Publisher_Country
Africa Link	UK
AFRICA Today	UK
Africa World Review	UK
African Business	UK
African Soccer	UK
African Study Group	UK
African Times	UK
Alarm	UK
BECDF News	UK
bfm	UK
Black Arts in London	UK
Black Beauty & Hair	UK
Black Business & Culture	UK
Black Perspective	UK
Blackhair	UK
Blues & Soul	UK
B-TS Newsletter	UK
Bulletin of Francophone Africa	UK
Calabash	UK
Cameroon Monitor	UK
Carf Magazine	UK
Caribbean Environment Watch	UK
Christendom	UK
Complete Football International	UK
Crosscolour	UK
Development Team	UK
Focus	UK
Gargamel	UK
Ghana Review International	UK
Hip-Hop Connection	UK
Impact International	UK
Jazz Journal International	UK
Journal of the Anglo-Somali Society/Warsidaha Ururka Ingiriiska iyo Soomaalida	UK
Justice for Roger Sylvester	UK
L'Exile Africain	UK
Mango Season	UK
Mano Vision	UK
Mano Vision Newsletter	UK
Memento de l'economie africaine	UK
Memento de l'economie africaine	UK

Record: 1 of 64

Identifies name of resource.

Figure 12: Format: Magazine Query

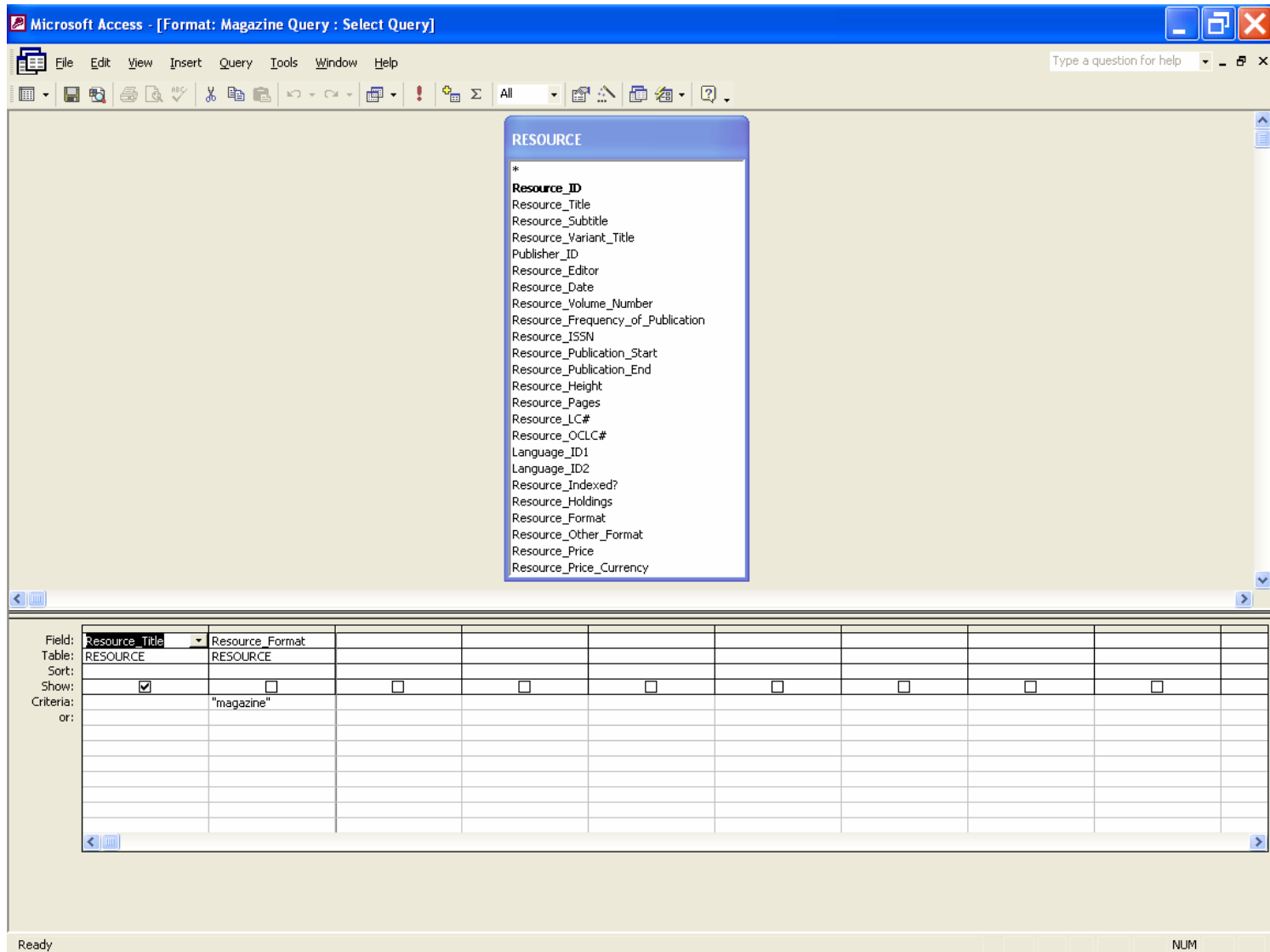

Figure 13: Format: Magazine Query Output

